

Property of
Sensata Technologies

REVISIONS					
ZONE	LTR	DEV. #	DESCRIPTION	DATE	APPROVED
	F	2CP	ADDED TO NOTE #2 "CONFORMING TO UL 1015" C.R. M44312	1-11-99	E.M.M. J.D.M.

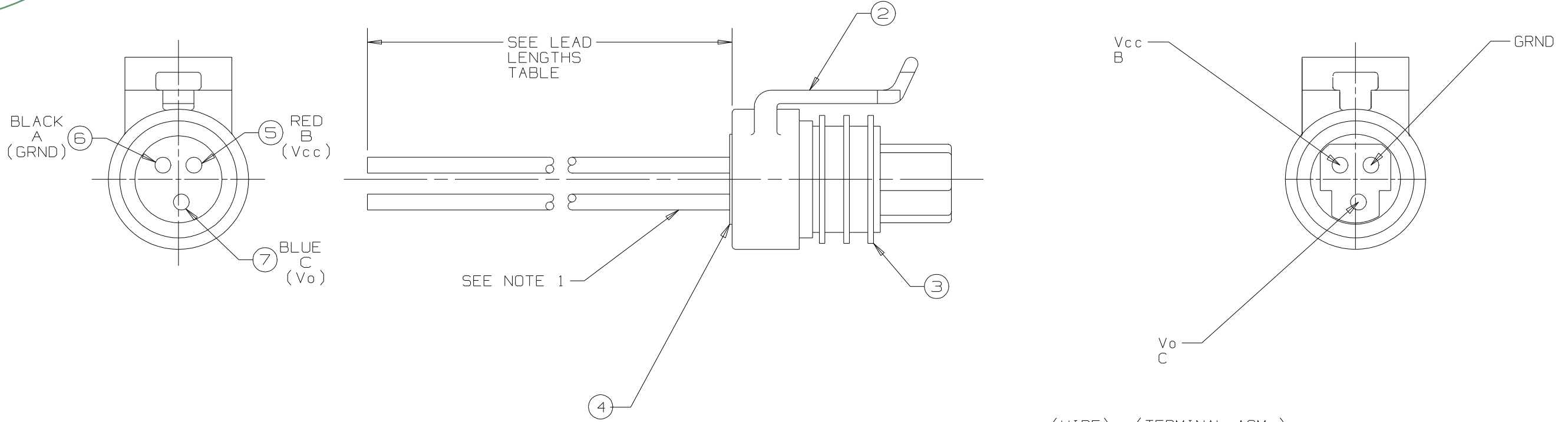

(WIRE) (TERMINAL ASM.)

QTY	WIRE	TERMINAL ASM.	DESCRIPTION
1	1	1	7 2832 & 12089290 WIRE AND TERMINAL ASM.
1	1	1	6 1074 & 12089290 WIRE AND TERMINAL ASM.
1	1	1	5 4886 & 12089290 WIRE AND TERMINAL ASM.
1	1	1	4 12065285 CABLE SEAL
1	1	1	3 12052893 CONNECTOR SEAL
1	1	1	2 12065286 CONNECTOR BODY
1			1 ASSEMBLY

NOTES:

- PULL TO SEAT WIRE AND TERMINAL ASSEMBLIES (3-PL.).
- EACH WIRE IS TO BE MADE UP OF TWISTED STRANDS CONSTITUTING A 22 GAUGE DIAMETER AND JACKETED WITH PVC INSULATION, CONFORMING TO UL 1015.

QUANTITY	ITEM NO	DESCRIPTION
-3 -2 -1	TM MORRIS(WIRE ONLY) & PACKARD ELECTRIC DIVISION PART NO.	
DASH NO		

THIS DRAWING SUPERSEDES 28810 REV."E" DATED 12-09-98.

DASH NO.	LENGTH
28810-3	117.5/118.5
28810-2	80.0/ 79.0
28810-1	40.0/ 39.0
LEAD LENGTHS	

UNLESS OTHERWISE SPECIFIED DIMENSIONS ARE IN INCHES	DRAWN O. LARSEN	DATE 12-20-96	RS	VS	M21	P35
TOLERANCES ON FRACTIONS DECIMALS ANGLES	ENGINEER SUCHARITA SAHU	12-20-96	 TEXAS INSTRUMENTS ATTLEBORO, MASSACHUSETTS 02703			
MATERIAL	APPROVED D. R. SOGGE	12-20-96	 CONTROL PRODUCTS DIVISION			
	APPROVED E. J. WILKINSON	12-20-96	TITLE WIRE HARNESS (UL 1015)			
	SIGNATURES ON FILE. REFER TO ELECTRONIC CHANGE NOTICE.		SIZE B	CODE IDENT NO. 82647	28810	