

DETAIL A  
SCALE 3.000

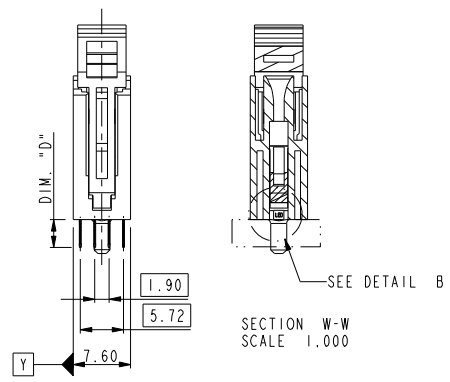

SECTION W-W  
SCALE 1.000

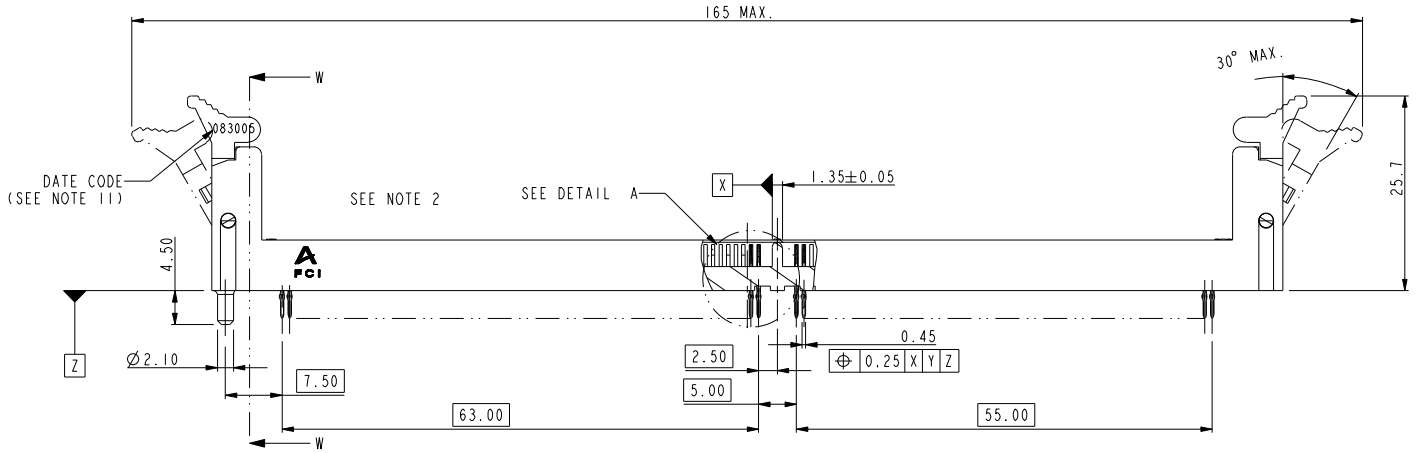
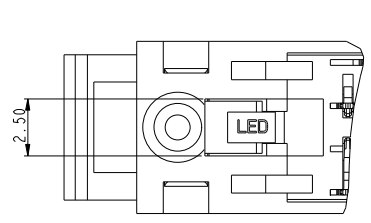
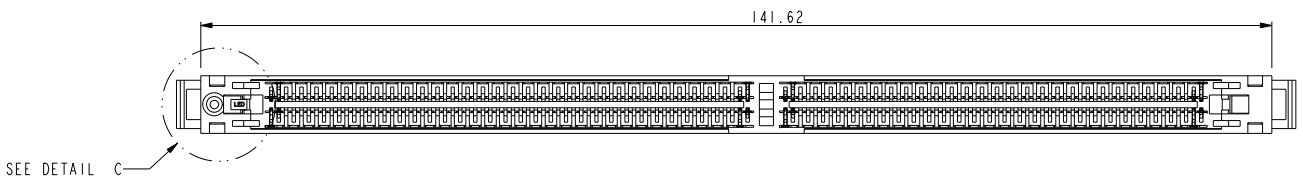

DETAIL C  
SCALE 3.000

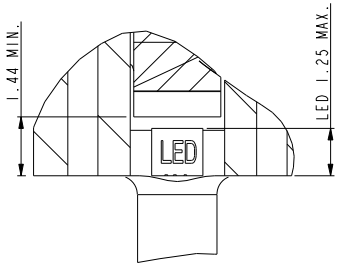

DETAIL B  
SCALE 5.000

Mark with 10034542 REV. P in area indicated by X.....			
rev	ecn no	dr	date
N	DG07-0306	CS	27/07/07
P	DG07-0416	CS	22/10/07

www.fciconnect.com			surface <input checked="" type="checkbox"/>	tolerance std	projection <input checked="" type="checkbox"/>	MM	
			TOLERANCES UNLESS OTHERWISE SPECIFIED				
Dr	CHARLIE S	02/10/04	ANGULAR	0.X ± .38	size A4	Scale 0.500	
Eng	CHARLIE S	02/10/04	LINEAR	0.XX ± .25	ECN	T04-0061	
Chr	HSIEH GARY	02/10/04	0° ± 2°	0.XXX ± .13	Spec ref	*	
Appr	JOSEPH HSIA	02/10/04	Product family				
FCI			title DDR 11 240P PRESS-FIT			dwg no 10034542	Rev. P
			catalog			CUSTOMER	

PDM: Rev:P

STATUS: Released

Printed: Jul 28, 2010



Copyright FCI.

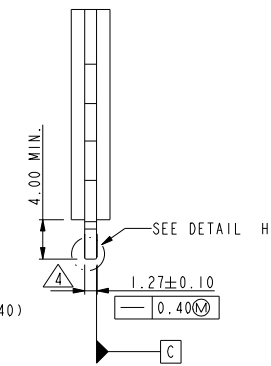
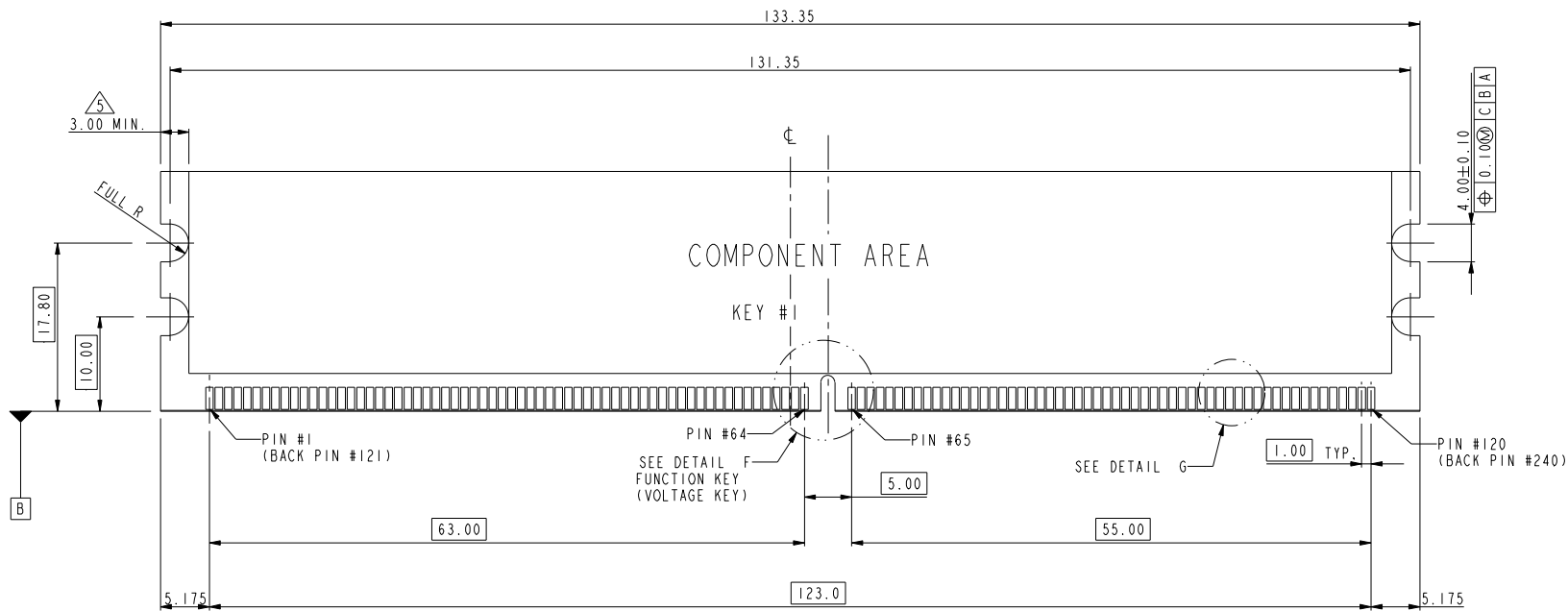

DETAIL H  
SCALE 3.000  
C0.10

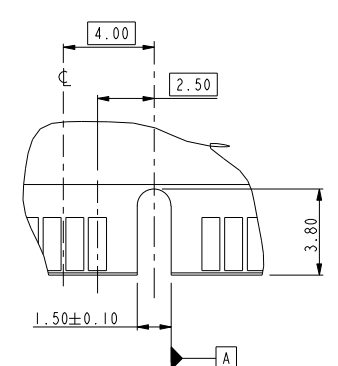

DETAIL F  
KEY POSITION #1  
TYPE "C"

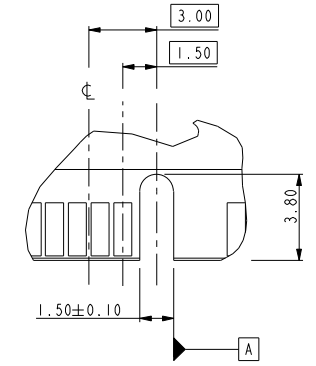

DETAIL F  
KEY POSITION #1  
TYPE "L"

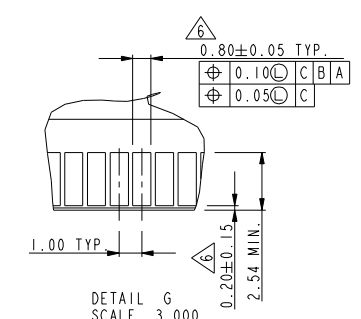

DETAIL G  
SCALE 3.000

NOTE:  
1. MATERIAL : FR-4.  
2. FINISH: SOLDER MASK.  
3. BURR: 0.08 MAX.

TYPE "L"	2.5 VOLTAGE
TYPE "C"	1.8 VOLTAGE
SUB KEY POS #1	DESCRIPTION

tolerance unless otherwise specified	
linear	.X ± .38
	.XX ± .25
	.XXX ± .13
angles	0° ± 2°

	title	DDR 11 240P PRESS-FIT	dwg no <b>10034542</b>	Rev. <b>P</b>
	catalog	PDM: Rev:P		
			sheet 2 of 4	Printed: Jul 28, 2010



Copyright FCI.

2

3

4

A

A

B

B

C

C

D

D

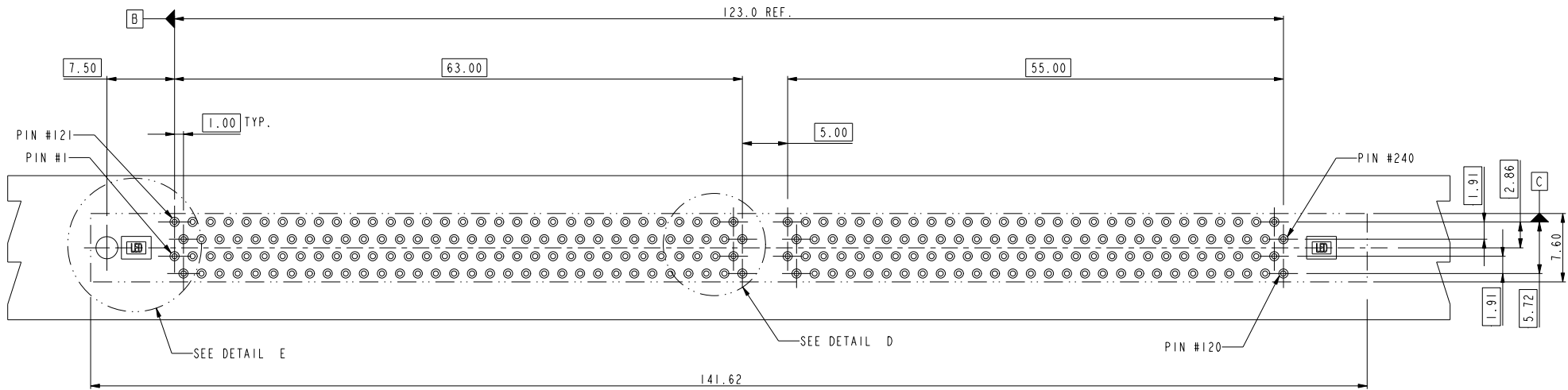

RECOMMEND CIRCUIT BOARD HOLE LAYOUT

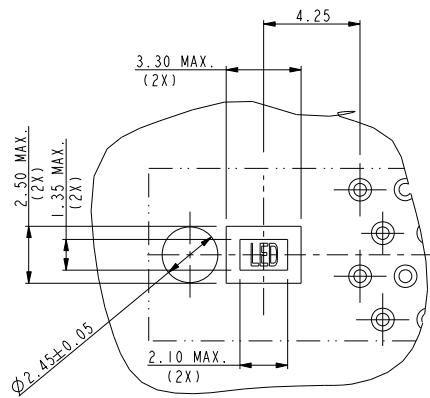

DETAIL E  
SCALE 3.000

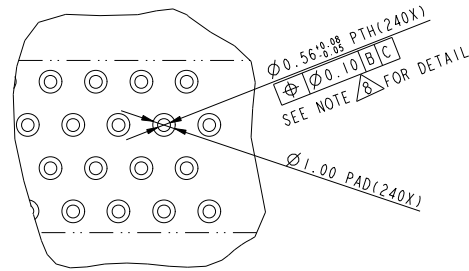

DETAIL D  
SCALE 3.000

tolerance unless otherwise specified	
linear	.X ± .38
	.XX ± .25
	.XXX ± .13
angles	0° ± 2°

	title <b>DDR II 240P PRESS-FIT</b>	dwg no <b>10034542</b>	Rev. <b>P</b>
	catalog	PDM: Rev-P	STATUS: Released



Copyright FCI.

10034542-□ □ □ □

STYLE: MECHANICAL KEYING

1 : 1.8 VOLT. W/CENTER KEY #1  
 2 : 2.5 VOLT. W/LEFT KEY #1

REVISE

0

TAIL LENGTH

CODE	DIM. "D"
0	3.30
1	3.70
2	4.20

PLATING

CODE	CONTACT	TAIL AREA	UNDERPLATE	CODE	CONTACT	TAIL AREA	UNDERPLATE
2	15u" (0.38um) MIN. GOLD	35u"~100u" Tin PLATING	50u" (1.27um) MIN. NICKEL OVERALL	2B	15u" (0.38um) MIN. GOLD	35u"~100u" Tin/Lead PLATING	50u" (1.27um) MIN. NICKEL OVERALL
3	30u" (0.76um) MIN. GOLD			3B	30u" (0.76um) MIN. GOLD		
4	3u" (0.076um) MIN. GOLD			4B	3u" (0.076um) MIN. GOLD		
6	15u" (0.38um) MIN. GOLD (LUBRICATED)	35u"~100u" Tin PLATING	50u" (1.27um) MIN. NICKEL OVERALL	6B	15u" (0.38um) MIN. GOLD (LUBRICATED)	35u"~100u" Tin/Lead PLATING	50u" (1.27um) MIN. NICKEL OVERALL
7	30u" (0.76um) MIN. GOLD (LUBRICATED)			7B	30u" (0.76um) MIN. GOLD (LUBRICATED)		
8	3u" (0.076um) MIN. GOLD (LUBRICATED)			8B	3u" (0.076um) MIN. GOLD (LUBRICATED)		
2LF	15u" (0.38um) MIN. GOLD	35u"~100u" Tin PLATING	50u" (1.27um) MIN. NICKEL OVERALL				
3LF	30u" (0.76um) MIN. GOLD						
4LF	3u" (0.076um) MIN. GOLD						
6LF	15u" (0.38um) MIN. GOLD (LUBRICATED)	35u"~100u" Tin PLATING	50u" (1.27um) MIN. NICKEL OVERALL				
7LF	30u" (0.76um) MIN. GOLD (LUBRICATED)						
8LF	3u" (0.076um) MIN. GOLD (LUBRICATED)						

COLOR OF HOUSING AN EJECTOR

- 0 : BLACK HOUSING + IVORY EJECTOR
- 1 : BLACK HOUSING + AMBER EJECTOR
- 2 : BLACK HOUSING + BLACK EJECTOR
- 3 : BLUE HOUSING + IVORY EJECTOR
- 4 : BLUE HOUSING + AMBER EJECTOR

NOTE:

1. MATERIAL:  
 HOUSING: HIGH PERFORMANCE RESINS, GLASS FILLED UL94V-0 RATED,  
 COLOR: BLACK.  
 EJECTOR: HIGH PERFORMANCE RESINS, GLASS FILLED UL94V-0 RATED,  
 COLOR: NATURAL.  
 TERMINAL: COPPER ALLOY.
2. FCI LOGO TO BE APPROXIMATELY LOCATED AS SHOWN ON PRINT.
3. PRODUCT SPECIFICATION: GS-12-273
- △ CARD THICKNESS APPLIES ACROSS TABS AND INCLUDES PLATING AND / OR METALIZATION.
- △ 3.00mm MINIMUM APPLIES TO BOTH 4.00mm WIDE NOTCH LENGTH AND COMPONENT KEEP-OUT AREA.
- △ LEADING EDGE OF CONTACT PADS SPECIFIED BY THE KEEP OUT ZONE SHALL BE FREE OF BURRS AND EXTERNAL TIE BARS. FOR OPTIMUM PERFORMANCE, THE TIE BAR IS TO BE ON AN INTERNAL LAYER SO THAT THE REMNANT CANNOT CAUSE CONTACT DAMAGE.
7. PACKAGING SPECIFICATION: GS-14-528.
- △ ALL PTH SHOULD BE 0.66mm DIA DRILLED AND 0.025mm MIN. ELECTRO-DEPOSITED COPPER THK ON THROUGH HOLE WALL.
9. THIS PRODUCT MEETS EUROPEAN UNION DIRECTIVES AND OTHER COUNTRY REGULATIONS AS DESCRIBED IN GS-22-008.
10. THE HOUSING WILL WITHSTAND EXPOSURE TO 260° PEAK TEMPERATURE FOR 20 SECONDS IN A IR REFLOW OVEN.

△ DATE CODE: X X X X X X

YEAR  
 DATE  
 MONTH

	title <b>DDR 11 240P PRESS-FIT</b>	dwg no <b>10034542</b>	Rev. <b>P</b>
	catalog <b>PDM: Rev:P</b>	STATUS <b>Released</b>	CUSTOMER sheet 4 of 4 Printed: Jul 28, 2010